

*TB 9-6625-2137-35

DEPARTMENT OF THE ARMY TECHNICAL BULLETIN

CALIBRATION PROCEDURE FOR VOLTMETER, FREQUENCY SELECTIVE AN/USM-490(), AND SELECTIVE LEVEL METER, HEWLETT-PACKARD, MODELS 3586B AND 3586C W/OPTIONS 001, 003, AND 004

Headquarters, Department of the Army, Washington, DC
15 March 2004

Distribution Statement A: Approved for public release, distribution is unlimited.

REPORTING OF ERRORS AND RECOMMENDING IMPROVEMENTS

You can improve this manual. If you find any mistakes or if you know of a way to improve these procedures, please let us know. Mail your letter or DA Form 2028 (Recommended Changes to Publications and Blank Forms) directly to: Commander, US Army Aviation and Missile Command, AMSAM-MMC-MA-NP, Redstone Arsenal, AL 35898-5000. A reply will be furnished to you. You may also provide DA Form 2028 information to AMCOM via e-mail, fax, or the World Wide Web. Our fax number is DSN 788-6546 or Commercial 256-842-6546. Our e-mail address is 2028@redstone.army.mil. Instructions for sending an electronic 2028 may be found at the back of this manual. For the World Wide Web, use <https://amcom2028.redstone.army.mil>.

SECTION		Paragraph	Page
	I. IDENTIFICATION AND DESCRIPTION		
	Test instrument identification	1	2
	Forms, records, and reports.....	2	2
	Calibration description	3	2
	II. EQUIPMENT REQUIREMENT		
	Equipment required	4	4
	Accessories required.....	5	4
	III. CALIBRATION PROCESS		
	Preliminary instructions.....	6	6
	Equipment setup	7	6
	Center frequency	8	7
	Counter	9	7
	Return loss.....	10	7
	Balance.....	11	9
	Amplitude	12	12
	Half power bandwidth	13	14
	Bandpass flatness	14	15

*This bulletin supersedes TB 9-6625-2137-35, dated 31 December 1996.

	Paragraph	Page
400 Hz shape and 20 Hz pilot filters, bandwidth.....	15	15
Carrier frequency and adjacent channel rejection.....	16	16
Wideband power flatness.....	17	16
Phase and residual phase jitter (option 003 only)	18	17
Final procedure	19	18

**SECTION I
IDENTIFICATION AND DESCRIPTION**

1. Test Instrument Identification. This bulletin provides instructions for the calibration of Voltmeter Frequency Selective AN/USM-490(), and Selective Level Meter, Hewlett-Packard, Models 3586B and 3586C w/Options 001, 003, and 004. The manufacturer’s manual was used as the prime data source in compiling these instructions. The equipment being calibrated will be referred to as the TI (test instrument) throughout this bulletin.

a. Model Variations. Variations among models are described in text.

b. Time and Technique. The time required for this calibration is approximately 12 hours, using the dc and low frequency technique.

2. Forms, Records, and Reports

a. Forms, records, and reports required for calibration personnel at all levels are prescribed by TB 750-25.

b. Adjustments to be reported are designated (R) at the end of the sentence in which they appear. When adjustments are in tables, the (R) follows the designated adjustments. Report only those adjustments made and designated with (R).

3. Calibration Description. TI parameters and performance specifications which pertain to this calibration are listed in table 1.

Table 1. Calibration Description

Test instrument parameters	Performance specifications
Bandwidth selectivity	Range: 20, 400, and 3100 Hz Accuracy: 3 dB bandwidth ±10%

Table 1. Calibration Description Continued

Test instrument parameters	Performance specifications	
Amplitude ¹	Range: 75 Ω /50 Ω input -80 to +20 dBm 200 Hz to 20 kHz 20 kHz to 18 MHz 18 to 32.5 MHz -100 to -80 dBm 200 Hz to 20 kHz 20 kHz to 32.5 MHz 124 Ω input ² -80 to +20 dBm 4 to 10 kHz 10 to 50 kHz 50 kHz to 5 MHz 5 to 10 MHz 124 Ω input ² -100 dB to -80 dBm 10 to 50 kHz 50 kHz to 5 MHz 5 to 10 MHz 135 Ω, 150 Ω input ² -80 to +20 dBm 50 kHz to 1 MHz 10 to 50 kHz 4 to 10 kHz -100 to -80 dBm 50 kHz to 1 MHz 10 to 50 kHz 600 Ω input 100 Hz to 108 kHz -80 to +20 dBm -100 to -80 dBm	Accuracy ±0.40 dB ±0.20 dB ±0.25 dB ±0.95 dB ±0.75 dB ±0.60 dB ±0.50 dB ±0.35 dB ±0.50 dB ±1.00 dB ±0.75 dB ±1.00 dB ±0.35 dB ±0.50 dB ±0.60 dB ±0.75 dB ±1.00 dB ±0.35 dB ±0.75 dB
Tuned frequency	Range: 200 Hz to 32.5 MHz Accuracy: 1 X 10 ⁻⁵ /year (±2 x 10 ⁻⁷)/year w/option 004	
Counter	Range: 50 Hz to 32.5 MHz Accuracy: ±1 Hz	
Wide band power flatness	Range: 200 Hz to 32.5 MHz Accuracy: 200 Hz to 20 kHz 20 kHz to 10 MHz 10 to 32.5 MHz	±2 dB ±1.0 dB ±2 dB
Return loss	Range: 75 Ω/50 Ω input: 50 Hz to 32.5 MHz 124 Ω input: ² 4 to 6 kHz 6 to 10 kHz 10 kHz to 5 MHz 135 Ω input: ² 4 to 6 kHz 6 to 10 kHz 10 kHz to 1 MHz 600 Ω input: 50 Hz to 108 kHz	30 dB 20 dB 25 dB 30 dB 20 dB 25 dB 30 dB 25 dB

See footnotes at end of table.

Table 1. Calibration Description Continued

Test instrument parameters	Performance specifications												
Phase jitter	Demodulated tone frequency range: 960 to 1060 Hz Accuracy: $\pm(10\% +.5^\circ \text{ p-p})$ Input signal level: $\leq 30 \text{ dB below FS, } -65 \text{ dBm}$ Residual range jitter: $\leq .5^\circ \text{ p-p (50 kHz to 32.5 MHz)}$												
Balance	Range: 50 Hz to 10 MHz Accuracy: <table border="0" style="display: inline-table; vertical-align: middle;"> <tr> <td style="text-align: center;"><u>Input Frequency</u></td> <td style="text-align: center;"><u>Balance</u></td> <td></td> </tr> <tr> <td style="text-align: center;">124 Ω</td> <td style="text-align: center;">10 kHz to 10 MHz</td> <td style="text-align: center;">-36 dB</td> </tr> <tr> <td style="text-align: center;">135 Ω</td> <td style="text-align: center;">10 kHz to 1 MHz</td> <td style="text-align: center;">-36 dB</td> </tr> <tr> <td style="text-align: center;">600 Ω</td> <td style="text-align: center;">50 Hz to 108 kHz</td> <td style="text-align: center;">-40 dB</td> </tr> </table>	<u>Input Frequency</u>	<u>Balance</u>		124 Ω	10 kHz to 10 MHz	-36 dB	135 Ω	10 kHz to 1 MHz	-36 dB	600 Ω	50 Hz to 108 kHz	-40 dB
<u>Input Frequency</u>	<u>Balance</u>												
124 Ω	10 kHz to 10 MHz	-36 dB											
135 Ω	10 kHz to 1 MHz	-36 dB											
600 Ω	50 Hz to 108 kHz	-40 dB											
Adjacent channel rejection	Range: Bandwidth 3100 Hz Accuracy: 75 dB minimum $\pm 2850 \text{ Hz}$												
Carrier channel rejection	Range: Bandwidth 20 Hz Accuracy: 30 dB $\pm 45 \text{ Hz}$ 60 dB $\pm 90 \text{ Hz}$ Range: Bandwidth 400 Hz Accuracy: 60 dB $\pm 1100 \text{ Hz}$ Range: Bandwidth $\pm 3100 \text{ Hz}$ Accuracy: 60 dB $\pm 1850 \text{ Hz}$ Range: Bandwidth 400 Hz $\pm 1100 \text{ Hz}$ at 60 dBm 0 rejection Pilot (20 Hz) filter bandwidths: Range: $\pm 45 \text{ Hz}$ at 30 dBm 0 rejection Range: $\pm 90 \text{ Hz}$ at 60 dBm 0 rejection												
Band pass flatness	Range: Bandwidth 3100 Hz $\pm 1000 \text{ Hz}$ Accuracy: $\pm 0.3 \text{ dB}$ Range: Bandwidth 400 Hz $\pm 50 \text{ Hz}$ Accuracy: $\pm 0.3 \text{ dB}$ Range: Bandwidth 20 Hz $\pm 3 \text{ Hz}$ Accuracy: $\pm 0.3 \text{ dB}$												

¹Range specifications calibrated to -100 dBm to +20.

²Not applicable for model 3586C.

SECTION II EQUIPMENT REQUIREMENTS

4. Equipment Required. Table 2 identifies the specific equipment to be used in this calibration procedure. This equipment is issued with Secondary Transfer Calibration Standards Set AN/GSM-287, or AN/GSM-705. Alternate items may be used by the calibrating activity. The items selected must be verified to perform satisfactorily prior to use and must bear evidence of current calibration. The equipment must meet or exceed the minimum use specifications listed in table 2. The accuracies listed in table 2 provide a four-to-one ratio between the standard and TI. Where the four-to-one ratio cannot be met, the actual accuracy of the equipment selected is shown in parenthesis.

5. Accessories Required. The accessories listed in table 3 are issued as indicated in paragraph 4 above and are used in this calibration procedure. When necessary, these items may be substituted by equivalent items, unless specifically prohibited.

Table 2. Minimum Specifications of Equipment Required

Common name	Minimum use specifications	Manufacturer and model (part number)
ATTENUATOR	Range: 0 to -40 dB Accuracy: Test report	Hewlett-Packard, Model 355D (355D)
CALIBRATOR	Ac voltage Range: 2.73861 mV to 2.738613 V Frequency: 200 Hz to 1 MHz Accuracy: $\pm 0.57\%$ >9.0 mV $\pm 2.07\%$ <9.0 mV dBm output Range: 0 to -30 dBm Frequency: 20 kHz Accuracy: $\pm 0.57\%$ Wideband ac voltage Range: 0.273861 V Frequency: 2 to 30 MHz (1.0 kHz reference) Amplitude flatness: $\pm 0.57\%$ (1.0% at 18 and 30 MHz)	Fluke, Model 5720A (5700A/EP) (p/o MIS-35947); w/divider, 7405A-4207 (7405A-4207)
FREQUENCY COUNTER	Range: 10 MHz Accuracy: 5×10^{-10}	Fluke, Model PM6681/656 (PM6681/656)
FUNCTION / ARBITRARY GENERATOR	Range: 50 Hz to 20 MHz +8.7 to -56 dBm Accuracy: ± 0.1 dB	Agilent, Model 33250A (33250A)
MULTIMETER	Range: 0.273861 V ac Accuracy: Nominal	Hewlett-Packard, Model 3458A (3458A)
SYNTHESIZER/ LEVEL GENERATOR	Range: 1 kHz to 32.5 MHz +10 to -100 dBm Accuracy: ± 0.1 dB	Hewlett-Packard, Model 3335AOPT001-K06 (MIS-35938)
TRUE RMS VOLTMETER	Range: 0 to -30 dBm Accuracy: ± 0.1 dBm	Fluke, Model 8922A/AA (8922A/AA)

Table 3. Accessories Required

Common name	Description (part number)
ADAPTER NO. 1 ¹	BNC plug to phone plug to Weco, Model 347 (052761297)
ADAPTER NO. 2 ¹	BNC plug (large) to Weco, Model 1250-591, Weco, Model 358 (14949A01W)
ADAPTER NO. 3	Male WECO 310 to female BNC adapter (3586B only)
BALANCE TEST ADAPTER	124 Ω balance test adapter, 4 BNC jack terminations (7916895)
BALANCE TEST ADAPTER	135 Ω balance test adapter, 4 BNC jack terminations (7916896)
BALANCE TEST ADAPTER	600 Ω balance test adapter, 3 BNC jack terminations (7916897)
BRIDGE	124 Ω return loss bridge, Hewlett-Packard, Model 5061-1137
BRIDGE, DIRECTIONAL	75 Ω directional bridge, Hewlett-Packard, Model 8721AOPT008 (8721AOPT008)
CABLE NO. 1 ²	75 Ω impedance; BNC plug terminations, 1 ft test cable (7916964-1)
CABLE NO. 2 ¹	75 Ω impedance BNC plug terminations, 2 ft test cable (7916964-2)
COMBINER POWER	3 BNC plug terminations power combiner (7916899)
MINIMUM LOSS PAD ¹	50 Ω to 75 Ω , impedance matching, BNC plug to BNC jack (Wavetek, Model M-157)
TERMINATION	75 Ω feedthrough; BNC plug to BNC jack, Hewlett-Packard, Model 11094B

¹Two required.

²Three required.

SECTION III CALIBRATION PROCESS

6. Preliminary Instructions

a. The instructions outlined in paragraphs 6 and 7 are preparatory to the calibration process. Personnel should become familiar with the entire bulletin before beginning the calibration.

b. Items of equipment used in this procedure are referenced within the text by common name as listed in table 2.

c. Unless otherwise specified, verify the result of each test and, whenever the test requirement is not met, take corrective action before continuing with the calibration. Adjustments required to calibrate the TI are included in this procedure. Additional maintenance information is contained in the manufacturer's manual for this TI.

d. Unless otherwise specified, all controls and control settings refer to the TI.

7. Equipment Setup

WARNING

HIGH VOLTAGE is used or exposed DEATH ON CONTACT during the performance of this calibration may result if personnel fail to observe safety precautions. REDUCE OUTPUT(S) to minimum after each step within the performance check where applicable.

NOTE

The oxidation of the battery mounted on circuit board A80 is causing the traces to corrode; in some cases the corrosion extends down into the connector. Before calibrating the AN/USM-490, the circuit board A80 should be removed and thoroughly cleaned. It may be necessary to replace the battery.

a. Remove protective cover only as required for access to adjustments or test points. Replace cover after completing the adjustments.

b. Connect TI to a 115 V ac source.

c. Energize TI and allow at least 20 minutes for warm-up and stabilization.

d. After warm-up, verify indicators listed in (1) through (5) below are on:

(1) [AUTO CAL].

(2) MEASUREMENT/ENTRY RANGE [10 dB]; FULL SCALE [AUTO]; and UNIT [dBm].

(3) FREQUENCY/ENTRY ENTRY FREQUENCY SSB CHANNEL [CARRIER]; CHANNEL [], and CNTR FREQ 1000.0000 kHz.

(4) MEASUREMENT MODE [LO DIST] and TERMINATION [10 k Ω | 1150 pF].

(5) **BANDWIDTH [3100 Hz]**.

8. Center Frequency

a. Performance Check

(1) Connect **10 MHz OUTPUT** on rear panel of TI to input of frequency counter.

(2) If frequency counter does not indicate between 9,999,900 and 10,000,100 Hz (9,999,998 and 10,000,002 Hz option 004), perform **b** below.

b. Adjustments. Adjust TI 10 MHz reference (on 10 MHz oven assembly) located on left rear corner) for 10,000,000 Hz (R).

9. Counter

a. Performance Check

NOTE

Unless otherwise specified, all cables will be RG58/4 BNC plug terminations.

(1) Connect equipment as shown in figure 1.

(2) Press TI **ENTRY [RECALL] [0]** and **TERMINATION [75 Ω]** pushbuttons.

(3) Set attenuator switch to -20 dB.

(4) Set synthesizer/level generator for 1 MHz and amplitude for -72 dBm output.

(5) Set synthesizer/level generator for 0.1 dB steps and press decrement pushbutton until TI indicates -100 dBm.

(6) Press TI **FREQUENCY/ENTRY [COUNTER]** pushbutton. If display does not indicate between 999,999.0 and 1,000,001.0 Hz, perform **b** below.

b. Adjustments. Adjust A22R6 (top front center of TI) for 1,000,000 Hz indication on TI counter (R).

10. Return Loss

a. Performance Check

(1) Connect equipment as shown in figure 2.

(2) Press TI **ENTRY [RECALL] [0]** and **TERMINATION [75 Ω]** pushbuttons.

(3) Set synthesizer/level generator for 1 MHz and amplitude for 0.0 dBm.

(4) Position true RMS voltmeter controls as listed in (a) through (d) below:

(a) **FUNCTION** switches **OUT**.

(b) **RANGE** switches **OUT**.

(c) **DISPLAY** switches **OUT**.

(d) **dBm REFERENCE Ω** control to **75**.

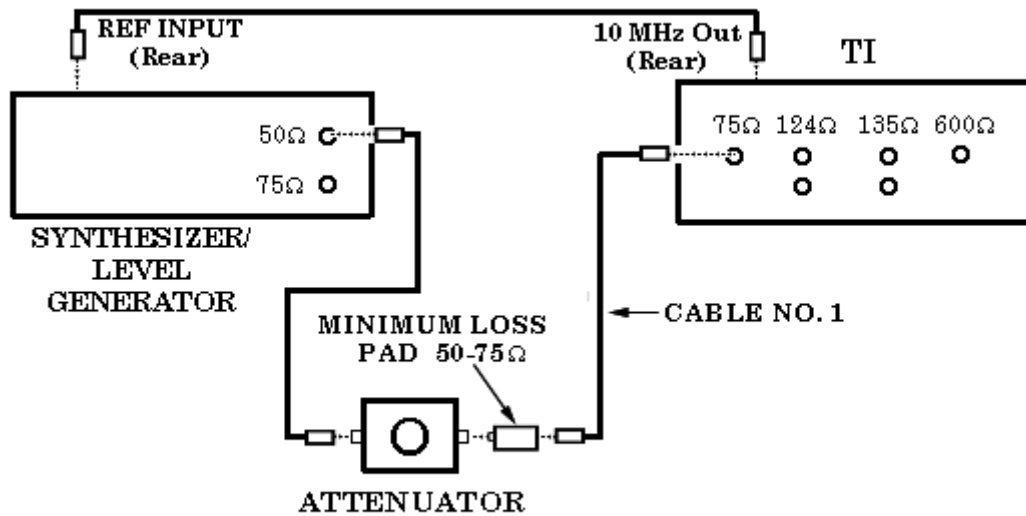

Figure 1. Counter check - equipment setup.

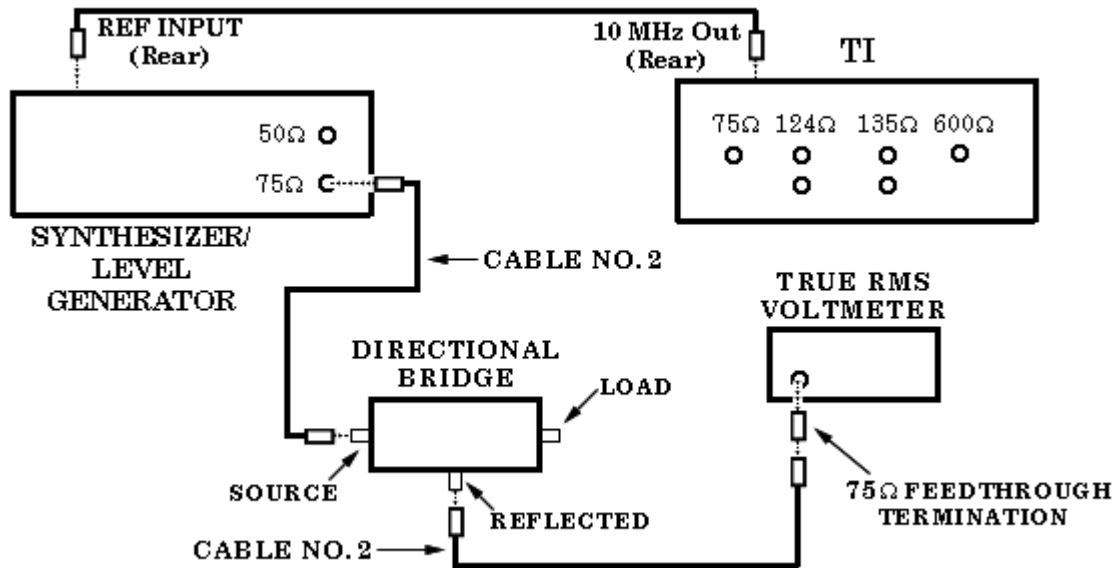

Figure 2. Return loss equipment setup.

(5) Press true rms voltmeter **DISPLAY dB/VOLTS** pushbutton for **dB**, and press **dBm/ REL** pushbutton for a **0.00 dB** indication.

(6) Connect cable No. 1 from directional bridge **LOAD** jack to TI **TERMINATION 75 Ω** input jack.

- (7) True rms voltmeter will indicate at least -30 dB down.
- (8) Disconnect cable No. 1 from TI **TERMINATION 75 Ω** input jack.
- (9) Set synthesizer/level generator for 10 MHz.
- (10) Press TI **ENTRY [FREQ] [1] [0] [MHz-dB]** pushbuttons for **10 MHz**.
- (11) Press true rms voltmeter **DISPLAY REL/dBm** pushbutton for a **0.00 dB** indication and repeat (6) through (8) above.

NOTE

Steps (12) through (21) below do not apply for model 3586C.

- (12) Replace directional bridge with return loss bridge in equipment setup.
- (13) Connect synthesizer/level generator **75 Ω OUTPUT** to return loss bridge source input, using cable No. 2.
- (14) Connect true rms voltmeter input to return loss bridge detector output, using cable No. 2.

NOTE

Ensure **MEASURE/TEST 30 dB** switch on return loss bridge is in **MEASURE** position.

- (15) Set synthesizer/level generator for 1 MHz.
- (16) Press TI **ENTRY [FREQ] [1] [MHz-dB]** pushbuttons for **1 MHz** and **TERMINATION [124 Ω]** pushbutton.
- (17) Set true rms voltmeter **REF** switch to **124 Ω** and press **DISPLAY REL/dBm** pushbutton for **0.00 dB** indication.
- (18) Connect return loss bridge to TI **TERMINATION 124 Ω** input jack.
- (19) True rms voltmeter will indicate at least -30 dB down.
- (20) Disconnect return loss bridge from TI.
- (21) Repeat (15) through (20) above for 5 MHz.

b. Adjustments. No adjustments can be made.

11. Balance

a. Performance Check

- (1) Connect equipment as shown in figure 3.
- (2) Press TI **ENTRY [RECALL] [0]** and **TERMINATION [75 Ω]** pushbuttons.
- (3) Set function/arbitrary generator for 50 Hz and amplitude for +10 dBm output.
- (4) Press TI **ENTRY [FREQ] [5] [0] [Hz MIN], MEASUREMENT/ENTRY [AVE],** and **BANDWIDTH [20 Hz]** pushbuttons.

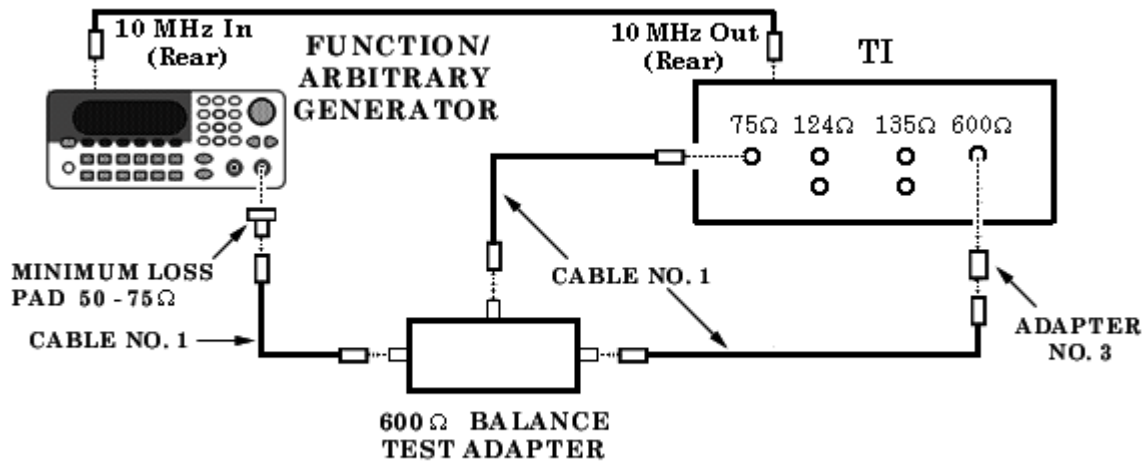

Figure 3. Balance test 600 Ω - equipment setup.

- (5) Press **TI MEASUREMENT/ENTRY [OFFSET]** and **ENTRY [RDNG OFFSET]** pushbuttons.
- (6) Disconnect cable No. 1 from TI 75 Ω input.
- (7) Press **TERMINATION [600 Ω]** pushbutton. TI will indicate less than or equal to -40 dBm O.
- (8) Reconnect cable No. 1 and repeat (2) through (7) above at 100 kHz.
- (9) Remove balance test 600 Ω adapter from setup.

NOTE

Steps (10) through (20) do not apply for model 3586C.

- (10) Connect equipment as shown in figure 4.

NOTE

Cable No. 1 must be the same length and capacitance for 10 MHz balance check.

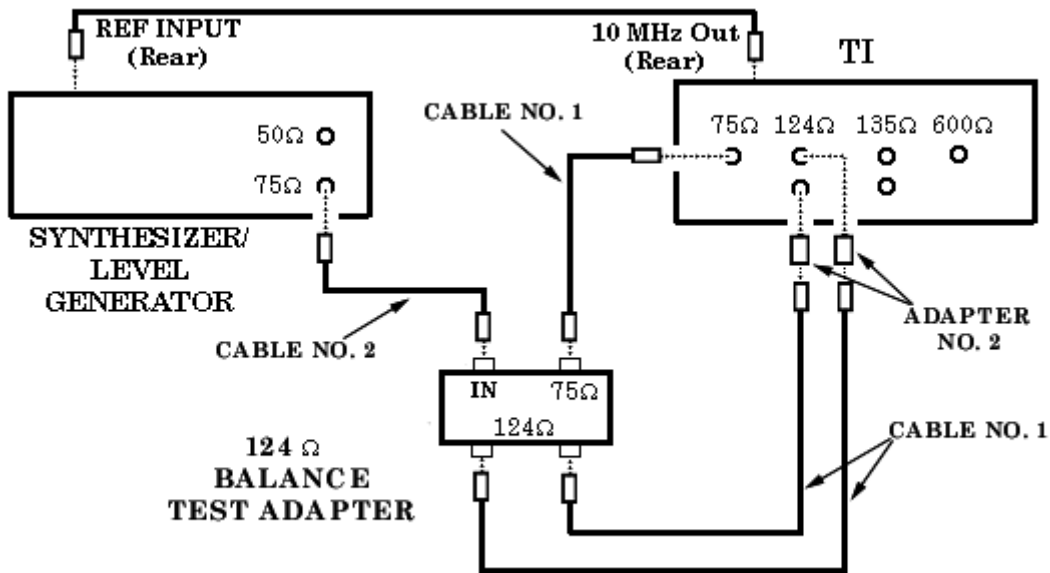

Figure 4. 124 Ω balance test - equipment setup.

- (11) Repeat (2) through (6) above at 10 kHz.
- (12) Press TI **TERMINATION [124 Ω]** pushbutton. TI will indicate less than or equal to -36 dBm O.
- (13) Repeat (11) and (12) above at 10 MHz.
- (14) Reverse connectors on **124 Ω** input. TI will indicate less than or equal to -36 dBm O.
- (15) Remove 124Ω balance test adapter from equipment setup and replace with 135Ω balance test adapter.
- (16) Remove adapters No. 2 from equipment setup and connect cables No. 1 to adapters No. 1.
- (17) Connect adapters No. 1 to **135 Ω** input of TI and repeat (2) through (6) above at 10 kHz.

NOTE

If indications between inputs are out of tolerance, replace one or both cables No. 1 and repeat (11) through (13) above.

- (18) Press TI **TERMINATION [135 Ω]** pushbutton. TI will indicate less than or equal to -36 dBm O.
- (19) Repeat (2) through (6) and (18) above at 1 MHz.
- (20) Repeat (14) above for 135 Ω input.

b. **Adjustments.** No adjustments can be made.

12. Amplitude

NOTE

If TI is meeting its amplitude accuracy specification for the 75 Ω input, it is reasonably certain that the other inputs (124 Ω, 135 Ω, 150 Ω, 600 Ω) will meet their specifications as well. Hence, further testing will not be required.

a. Performance Check

(1) Connect calibrator **OUTPUT** to multimeter **INPUT** terminals. Set multimeter for ac voltage measurements and set calibrator for a 0.273861V, 1 kHz output. Record multimeter indication (to be used in (15) below).

(2) Disconnect multimeter and connect calibrator **OUTPUT** to TI **10 Ω || 50 pF** input terminal. Press TI **ENTRY [RECALL] [0]** (pause until reset is completed) **[FREQ] [2] [0] [kHz]** pushbuttons; then press **BANDWIDTH [20 Hz]** pushbutton.

(3) Set calibrator output frequency to 20 kHz and voltage as listed in table 4. TI will indicate within the specified limits.

Table 4. dBm Accuracy (Part I)

Calibrator output	Test instrument indication (dBm)	
	Min	Max
.273861 V	-00.20	+00.20
.866025 V	+09.80	+10.20
2.738613 V ¹	+19.80	+20.20
Install ac divider ²		
2.73861 V	-39.80	-40.20
.866025 V	-49.80	-50.20
.273861 V	-59.80	-60.20
86.6025 mV	-69.80	-70.20
27.3861 mV	-79.80	-80.20
86.6025 mV ³	-89.25	-90.75
27.3861 mV	-99.25	-100.75

¹After obtaining TI indication press **ENTRY [RDNG OFFSET]** pushbuttons to store +20 dBm value.

²Press TI **AVE** pushbutton if required to stabilize indications.

³Press **MEASUREMENT ENTRY [OFFSET]** pushbuttons to offset TI indication by +20 dBm.

(4) Remove ac divider from equipment setup. Set calibrator for a 0 dBm, 20 kHz output.

(5) Press TI **MEASUREMENT/ENTRY [OFFSET]** pushbutton to off and allow TI to take several readings until an internal **CAL** cycle is completed.

(6) Press TI **ENTRY [RDNG OFFSET]** pushbutton; then press **MEASUREMENT/ENTRY [OFFSET]** pushbutton.

NOTE

The offset value should be approximately +9.03 dBm based on the formula: $\text{Offset} = 10 \log (600 \Omega / 75 \Omega)$ where 600 Ω is the calibrator dBm reference and 75 Ω is the TI dBm reference.

(7) With calibrator frequency at 20 kHz, set dBm output as listed in table 5. TI will indicate within the specified limits.

Table 5. dBm Accuracy (Part II)

Calibrator output (dBm)	Test instrument indication (dBm)	
	Min	Max
-1.0	-00.80	-01.20
-2.0	-01.80	-02.20
-3.0	-02.80	-03.20
-4.0	-03.80	-04.20
-5.0	-04.80	-05.20
-6.0	-05.80	-06.20
-7.0	-06.80	-07.20
-8.0	-07.80	-08.20
-9.0	-08.80	-09.20
-10	-09.80	-10.20
-20	-19.80	-20.20
-30	-29.80	-30.20

(8) Press TI **MEASUREMENT/ENTRY [OFFSET]** pushbutton (to off); then press **ENTRY [FREQ] [1]** and **[kHz]** pushbuttons.

(9) Set calibrator for a .273861 V, 1.0 kHz output. TI will indicate $\pm 00.00 (\pm 0.4)$ dBm.

(10) Set calibrator frequency to 200 Hz and set TI for a carrier frequency of 200 Hz by pressing **ENTRY [FREQ] [2] [0] [0]** and **[Hz]** pushbuttons. TI will indicate $\pm 00.00 (\pm 0.4)$ dBm.

(11) Repeat technique of (10) above for 10 and 15 kHz. TI will indicate $\pm 00.00 (\pm 0.4)$ dBm.

NOTE

In the following checks the TI bandwidth may be changed to either 400 Hz or 3100 Hz. However, if 20 Hz bandwidth is desired, TI carrier frequency can be fine tuned by utilizing TI **COUNTER** and **FREQUENCY TUNE** functions.

(12) Repeat technique of (10) above for 25, 100, and 500 kHz, and 1.0 MHz. TI will indicate $\pm 00.00 (\pm 0.2)$ dBm.

(13) Disconnect calibrator **OUTPUT** from TI.

TB 9-6625-2137-35

(14) Connect calibrator wideband to multimeter **INPUT** terminals. Set multimeter for ac voltage measurements and press calibrator **WBND** pushbutton.

(15) Set calibrator for an initial 0.273861 V, 1 kHz wideband output. Adjust calibrator for a multimeter indication equal to value recorded in (1) above (± 5 digits).

(16) Press calibrator **NEW REF** pushbutton; then set to **STBY**.

(17) Remove wideband output from multimeter and connect to TI **10 k || 50 pf** connector. Set calibrator **OPR/STBY** to **OPR**.

(18) Press TI **ENTRY [FREQ] [1] [kHz]** pushbuttons (pause until an internal **CAL** cycle is completed).

(19) Set calibrator frequency to 2 MHz and set TI for a carrier frequency of 2 MHz by pressing **ENTRY [FREQ] [2] [MHz]** pushbuttons. TI will indicate ± 00.00 (± 0.2) dBm.

(20) Repeat technique of (19) above for 15 MHz. TI will indicate ± 00.00 (± 0.2) dBm.

(21) Repeat technique of (19) above for 20 MHz. TI will indicate ± 00.00 (± 0.25) dBm.

b. Adjustments. No adjustments can be made.

13. Half Power Bandwidth

a. Performance Check

(1) Press TI pushbuttons as listed in (a) through (c) below:

(a) **[RECALL] [0]** and **AUTO CAL** (off).

(b) **[RECALL] [.]**, **[CNTR FREQ]**, and **[7]**.

(c) **MEASUREMENT/ENTRY [OFFSET]**, **ENTRY [RDNG OFFSET]**, **FREQUENCY TUNE [AUTO]**, and **BANDWIDTH [20 Hz]**.

NOTE

It may be necessary to press TI **FREQ STEP** pushbutton for fine tuning to get proper dBmO indication.

(2) Tune TI frequency control above 1 MHz for a -3 dBmO indication, and record frequency indication.

(3) Tune TI frequency control below 1 MHz for a -3 dBmO indication and subtract frequency reading from reading recorded in (2) above. The difference between the two frequencies will be between 18 and 22 Hz.

(4) Repeat (1) through (3) above for 400 Hz bandwidth. The difference between the two frequencies will be between 360 and 440 Hz.

(5) Repeat (1) through (3) above for 3100 Hz bandwidth. The difference between the two frequencies will be between 2790 and 3410 Hz.

b. Adjustments. No adjustments can be made.

14. Bandpass Flatness

a. Performance Check

(1) Press TI pushbuttons as listed in (a) through (c) below:

(a) [RECALL] [0] and AUTO CAL (off).

(b) [RECALL] [.] , [CNTR FREQ], and [7].

(c) MEASUREMENT/ENTRY [OFFSET], ENTRY [RDNG OFFSET], FREQUENCY TUNE [AUTO], and BANDWIDTH [20 Hz].

(2) Slowly tune frequency control to the first frequency above 1 MHz for a dBmO indication of ± 0.30 dBmO, and subtract 1 MHz from frequency reading. The difference will be greater than +3 Hz.

(3) Repeat (2) above to first frequency below 1 MHz for an indication of ± 0.30 dBmO and subtract reading from 1 MHz. The difference will be greater than -3 Hz.

(4) Repeat (1) through (3) above for 400 Hz ± 50 Hz bandwidth and for 3100 Hz ± 1000 bandwidth.

b. Adjustments. No further adjustments can be made.

15. 400 Hz Shape and 20 Hz Pilot Filters, Bandwidth

a. Performance Check

(1) Press TI pushbuttons as listed in (a) through (c) below:

(a) [RECALL] [0] and AUTO CAL (off).

(b) [RECALL] [.] , [CNTR FREQ] and [7].

(c) MEASUREMENT/ENTRY [OFFSET] ENTRY [RDNG OFFSET], FREQUENCY TUNE [AUTO], and BANDWIDTH [400 Hz].

(2) Tune TI frequency control to the first frequency above 1 MHz for an indication of -60 dBmO. Subtract 1 MHz from frequency reading. The difference will be equal to or less than +1100 Hz.

(3) Repeat (2) above to the first frequency below 1 MHz. Subtract frequency reading. The difference will be equal to or less than -1100 Hz.

(4) Repeat (1) above for 20 Hz bandwidth.

(5) Repeat (2) and (3) above for an indication of -30 dBmO. Subtract frequency readings above and below 1 MHz. The difference will be equal to or less than ± 45 Hz.

(6) Repeat (5) above for an indication of -60 dBmO. The difference will be equal to or less than ± 90 Hz.

b. Adjustments. No further adjustments can be made.

16. Carrier Frequency and Adjacent Channel Rejection

a. Performance Check

(1) Connect synthesizer/level generator **75 Ω OUTPUT** to **TI TERMINATION 75 Ω** input, using cable No. 2. Adjust frequency of synthesizer/level generator for 1 MHz and amplitude for 0 dBm output.

(2) Press **TI ENTRY [FREQ] [1]** and **[MHz-dB]** pushbuttons.

(3) Press **TI [RECALL], [0] TERMINATION (75 Ω) MEASUREMENT/ ENTRY [OFFSET],** and **ENTRY [RDNG OFFSET]** pushbuttons.

(4) Set synthesizer/level generator for an INCR frequency of 1850 Hz.

(5) Set synthesizer/level generator **INCR** pushbutton one step above 1 MHz. The TI dBmO level indication will be less than -60 dBmO.

(6) Repeat (5) above for one step below 1 MHz. The TI dBmO level indication will be less than -60 dBmO.

(7) Repeat (4) through (6) above for an INCR frequency of 2850 Hz. The TI dBmO level indication will be less than -75 dBmO.

b. Adjustments. No further adjustments can be made.

17. Wideband Power Flatness

a. Performance Check

(1) Connect equipment as shown in figure 5.

(2) Press **TI ENTRY [RECALL], [0], MEASUREMENT MODE [WIDE BAND], MEASUREMENT/ENTRY [AVE],** and **TERMINATION [75 Ω]** pushbuttons.

(3) Set function/arbitrary generator for 20 kHz and amplitude for +8.7 dBm.

(4) Set synthesizer/level generator for 30 kHz and amplitude for +8.7 dBm.

(5) Press **TI ENTRY [RDNG OFFSET]** and **MEASUREMENT/ENTRY [OFFSET]** pushbuttons.

(6) Set synthesizer/level generator to 10 MHz. TI will indicate between ± 0.8 dBmO.

(7) Set function/arbitrary generator for 200 Hz and synthesizer/level generator for 1 kHz. Press **TI [RDNG OFFSET]** pushbutton.

(8) Set synthesizer/level generator to 32 MHz. TI will indicate between ± 1.8 dBmO.

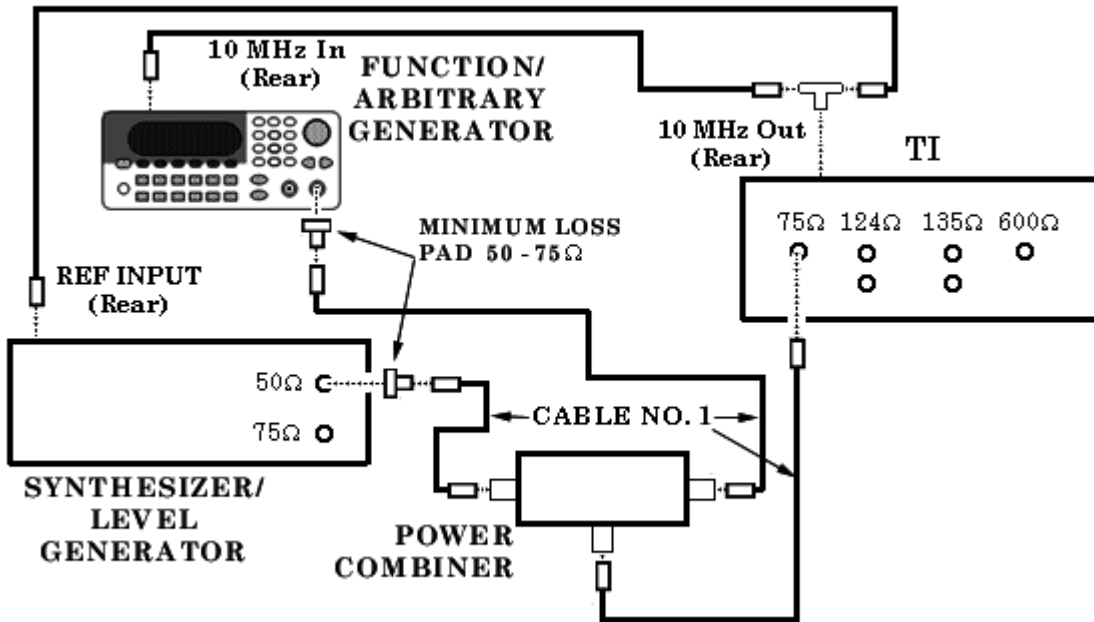

Figure 5. Wideband power accuracy setup.

(9) Set function/arbitrary generator and synthesizer/level generator for -36.3 dBm and repeat (3) through (8) above.

b. Adjustments. No further adjustments can be made.

18. Phase and Residual Phase Jitter (Option 003 Only)

a. Performance Check

- (1) Connect equipment as shown in figure 5.
- (2) Set TI ENTRY [RECALL], [0].
- (3) Set function/arbitrary generator frequency for 11004 Hz and amplitude for -56 dBm.
- (4) Set synthesizer/level generator frequency for 11104 Hz and set amplitude level to -76 dBm.
- (5) Press TI MEASUREMENT ENTRY RANGE [100 dB], and ENTRY, [FREQ], [1], [0], and [kHz +dB] pushbuttons.
- (6) Press TI MEASUREMENT MODE (blue) and [0 JITTER] pushbuttons. TI phase jitter will be from 10 to 13 degrees p-p.
- (7) Disconnect function/arbitrary generator and combiner power from setup.
- (8) Connect synthesizer/level generator 75 Ω OUTPUT to TERMINATION 75 Ω input of TI.
- (9) Press TI ENTRY [RECALL], [0], and TERMINATION [75 Ω] pushbuttons.

TB 9-6625-2137-35

(10) Set synthesizer/level generator for a frequency of 50 kHz and an amplitude level of -59.8 dBm.

(11) Press TI **MEASUREMENT/ENTRY, FULL SCALE [ENTRY], and RANGE [100 dB]** pushbuttons.

(12) Press TI **ENTRY [FULL SCALE], [3], [0], [MHz-dB], and [FREQ], [4], [8], [9], [9] [6], [Hz MIN]** pushbuttons.

(13) Press TI **MEASUREMENT/MODE** (blue) and **[0 JITTER]** pushbuttons. Residual phase jitter will be less than or equal to 0.5 degrees p-p.

(14) Adjust synthesizer/level generator for 2 MHz. Press **ENTRY/[FREQ], [1], [9],[9], [8], [9], [9], [6], and [Hz MIN]** pushbuttons.

(15) The TI phase jitter reading will be less than or equal to 0.5 degrees p-p.

b. Adjustments. No further adjustments can be made.

19. Final Procedure

a. Deenergize and disconnect all equipment and reinstall protective cover on TI.

b. Annotate and affix DA label/form in accordance with TB 750-25.

By Order of the Secretary of the Army:

Official:



JOEL B. HUDSON

*Administrative Assistant to the
Secretary of the Army*

0401501

PETER J. SCHOOMAKER

*General, United States Army
Chief of Staff*

Distribution:

To be distributed in accordance with the initial distribution number (IDN) 342243, requirements for TB 9-6625-2137-35.

INSTRUCTIONS FOR SUBMITTING AN ELECTRONIC 2028

The following format must be used if submitting an electronic 2028. The subject line must be exactly the same and all fields must be included; however, only the following fields are mandatory: 1, 3, 4, 5, 6, 7, 8, 9, 10, 13, 15, 16, 17, and 27.

From: "Whomever" whomever@redstone.army.mil

To: <2028@redstone.army.mil

Subject: DA Form 2028

1. **From:** Joe Smith
2. **Unit:** home
3. **Address:** 4300 Park
4. **City:** Hometown
5. **St:** MO
6. **Zip:** 77777
7. **Date Sent:** 19-OCT-93
8. **Pub no:** 55-2840-229-23
9. **Pub Title:** TM
10. **Publication Date:** 04-JUL-85
11. **Change Number:** 7
12. **Submitter Rank:** MSG
13. **Submitter FName:** Joe
14. **Submitter MName:** T
15. **Submitter LName:** Smith
16. **Submitter Phone:** 123-123-1234
17. **Problem:** 1
18. **Page:** 2
19. **Paragraph:** 3
20. **Line:** 4
21. **NSN:** 5
22. **Reference:** 6
23. **Figure:** 7
24. **Table:** 8
25. **Item:** 9
26. **Total:** 123
27. **Text**

This is the text for the problem below line 27.

